

Designer Fence



Installation Instructions

- It is the responsibility of the installer to meet all code and safety requirements, and to obtain all required building permits. The installer should determine and implement the installation techniques appropriate for each unique installation situation. Digger Specialties, Inc. and its distributors shall not be held liable for improper or unsafe installations.

Step 1: Layout Fence Line

Use a string to layout the fence line. On 8-foot sections, posts need to be 96" center to center (91" between posts).

NOTE: Post will be laid out with 5" side in parallel with rails. (See example.)

These are 3" x 5" posts, so the center of the posts will be 1½" off the string. Mark the ground where the centers of all holes will be. Dig all holes. We recommend having the bottom of the holes at least 36" deep, below the frost line and bell out the bottom of the holes to help prevent frost uplift. For 3" x 5" posts, 10" to 12" diameter holes are recommended.

If core drilling post into set concrete where water can build up, the installer is responsible to drill a ¼" weep hole as close to the bottom of the post by concrete as possible. If there is no weep hole, you may have damage from moisture build up and freezing thus potentially voiding the warranty.

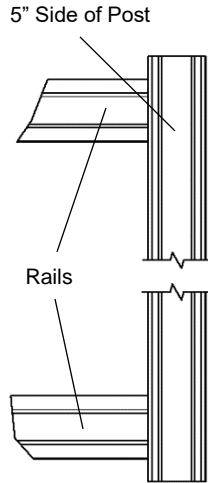

Step 2: Standard Post Install

To help achieve correct height for posts, set string at a certain height from the ground. The following example is using string set 10" off the ground.

Example: 72" Designer Fencing is 74" from the ground to the top of the post; subtract 10" (amount string is off the ground) from 74" (post height out of ground) = 64". Mark with a pencil 64" down from the top of all the posts.

Pour half a bag of concrete mix into the hole. Level the posts to the string and to the correct center to center measurement (you can use a spacer cut to the inside-to-inside measurement for this). Tap the post down until the pencil mark is at the string. Pour more concrete around the posts. We recommend the concrete be at least 8" below ground level. Set all posts. Make any final adjustments to line up the posts. Using a tamping rod, run it up and down through the concrete and around the post to help pack the concrete. Pour water on the concrete. For best results, let the concrete set up for at least a day.

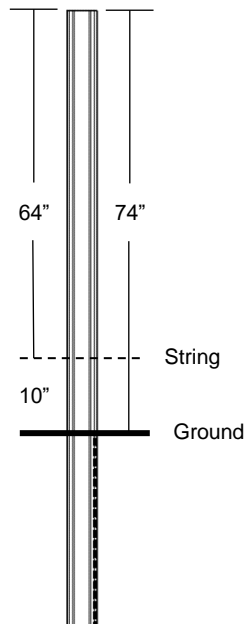

Sections installed on Standard Post will typically have 2" ground clearance.

Surface Mount Post spacing is 96" from center to center (91" between) posts for an 8-foot section.

Fasteners will need to be installed into concrete or wood to match Surface Mount Post hole configuration.

Sections on Surface Mount Posts will have 2½" ground clearance.

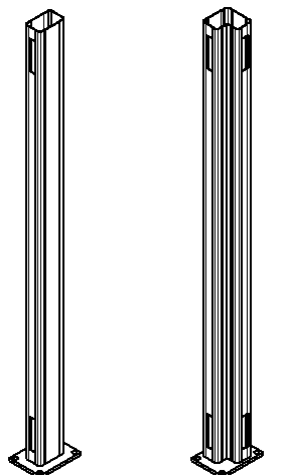

Line/End Post Corner Post

Step 3: Section Installation

Nest U-channel into groove on 3" side of post. Center between the top and bottom routed holes. Screw U-channel to post (screws provided), spacing screws evenly.

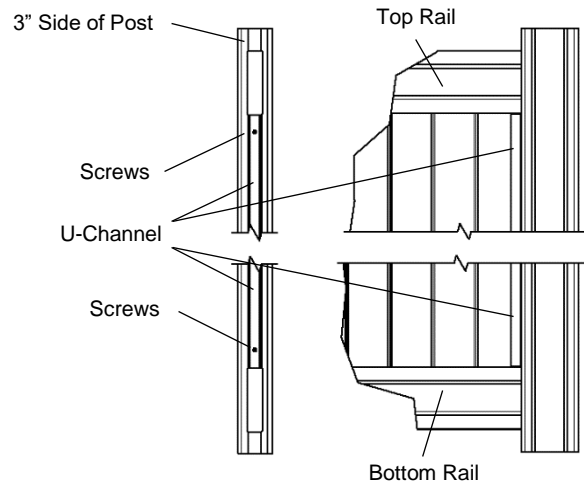

Depress snap lock and insert bottom rail into post. Let the rail go in until you can get the opposite side of the rail past the opposite post. Depress snap lock and insert opposite side of rail into post. Insert verticals into sections. If using Sienna infill, evenly space the three verticals with aluminum reinforcement, marked with stickers, throughout the section. Place top rail in section and lock into posts similar to bottom rail.

When installing sections that need to be racked, please refer to Step 3b: Racked Sections for further Installation recommendations.

Step 3a: Cutting Sections to Length

If sections need to be cut down, please note the following steps:

- All horizontal rails need to be drilled for snap lock if cut.
- All rails need to go inside of the post 1" on each side.
- New rail length = inside to inside of post + 2".
- The end verticals may need to be cut to desired width.

Step 3b: Racked Sections

Determine post center to center distance according to slope angle ensuring snap buttons on end of rails reach inside posts. **The greater the slope angle, the less the post center to center distance will be.**

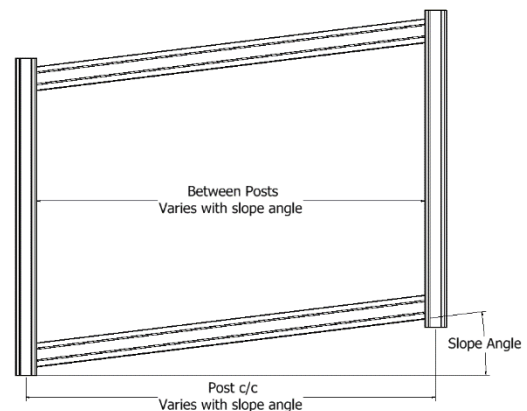

Remove snap buttons from rails on both ends.

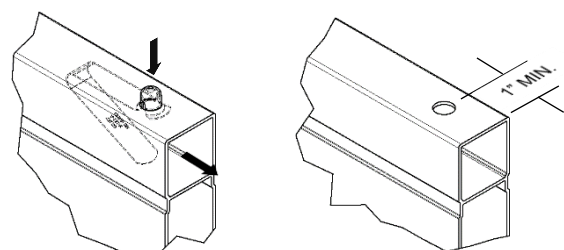

Designer Fence



Installation Instructions

- It is the responsibility of the installer to meet all code and safety requirements, and to obtain all required building permits. The installer should determine and implement the installation techniques appropriate for each unique installation situation. Digger Specialties, Inc. and its distributors shall not be held liable for improper or unsafe installations.

Step 3b: Racked Sections cont'd.

Drill 13/32" hole minimum 1" from end of rail to center of hole on both ends.

Reinstall snap buttons in new holes.

For more detailed Designer Fence racking information go to this link:
<https://www.diggerspecialties.com/site/wp-content/uploads/2021/11/Polyvinyl-Section-Racking-Help-Sheet-November2021.pdf>

Step 4: Attach Caps

Caps should be placed on posts after posts are installed. Secure caps by tapping them onto posts with a rubber mallet.

Step 5: Gate Installation

We recommend using heavy wall (.125") posts on both sides of gates. The gates are pre-assembled; however, the hinges and latches will need to be installed. Installation Instructions are provided with the gate hardware.

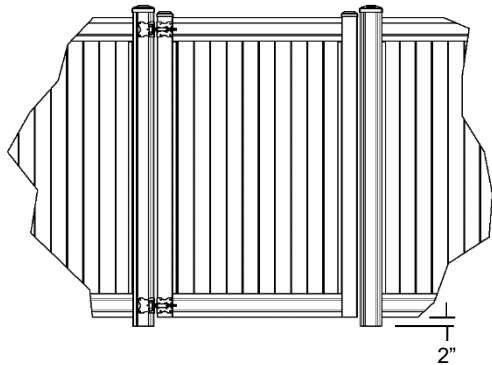

Gates with Standard Post installation will have 2" clearance between bottom of gate and ground level.

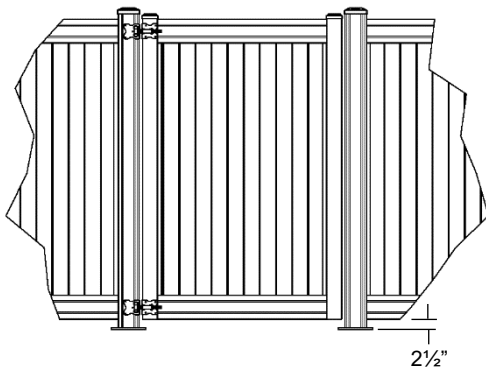

Gates with Surface Mount Post option will have 2 1/2" clearance between bottom of gate and ground level. Surface Mount Post option will require flairs to be installed.

Step 6: Flairs

Flairs will typically be used on Surface Mount Post options. The flairs consist of two inserts that are installed on top side of a two-piece flair and will fit around the Line/End Post or a Corner Post.

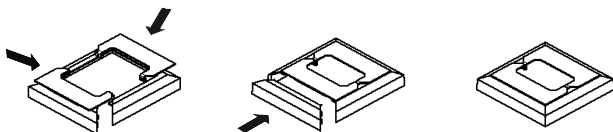

Flair Assembly for Line/End Post

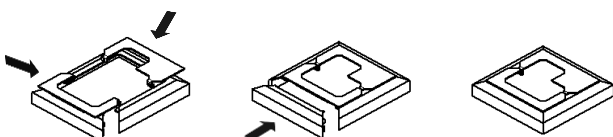

Flair Assembly for Corner Post

Care and Cleaning

Remove all particles and residue from Designer Fence vinyl and aluminum components by referring to the Care and Cleaning requirements on the DSI website.



SCAN ME

Warranty

For product Warranty and Registration please scan below:



SCAN ME