

# Bella Cavo Series

(Style C91)

## Gate Installation Instructions



- These instructions must be followed exactly as written, and the materials used must be exactly as shown in the instructions. Any deviation from the instructions or variation in the materials used/installed may result in an unsuccessful installation.

### Hinge Placement

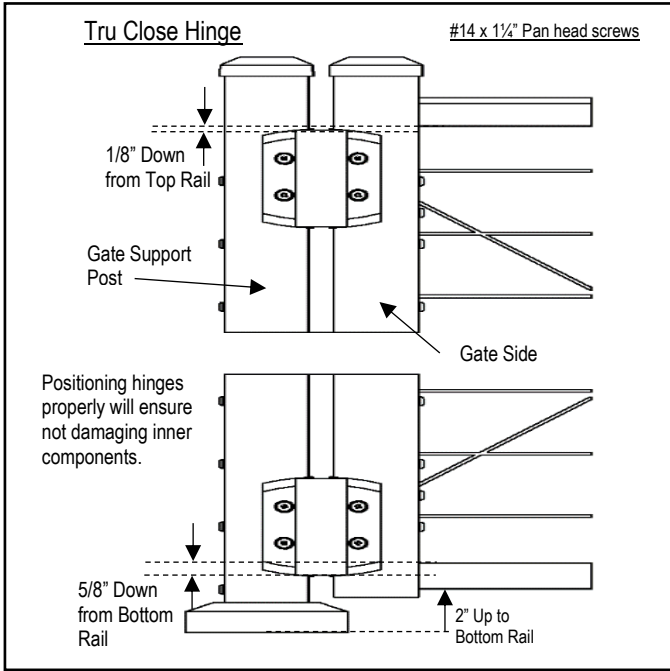

### Latch Placement

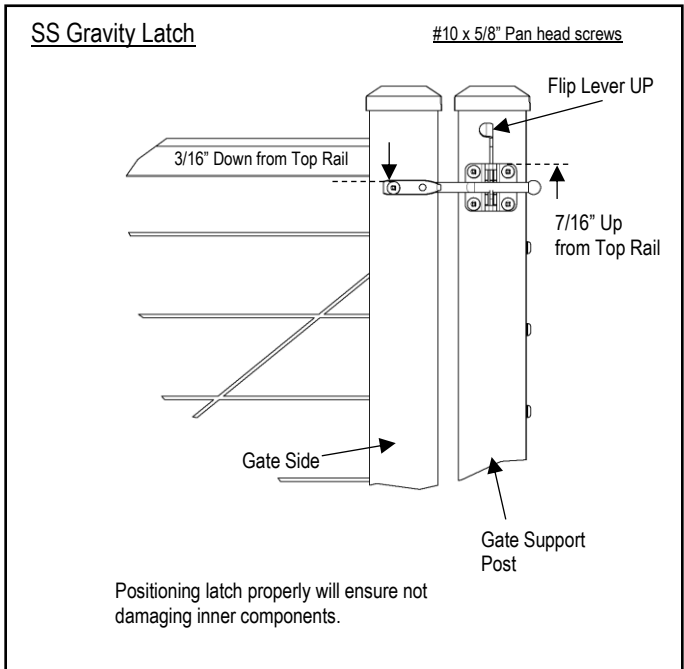
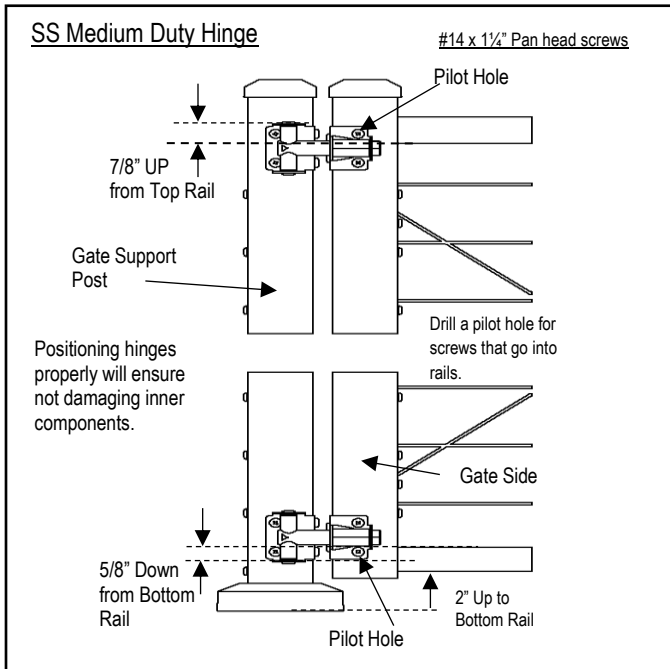
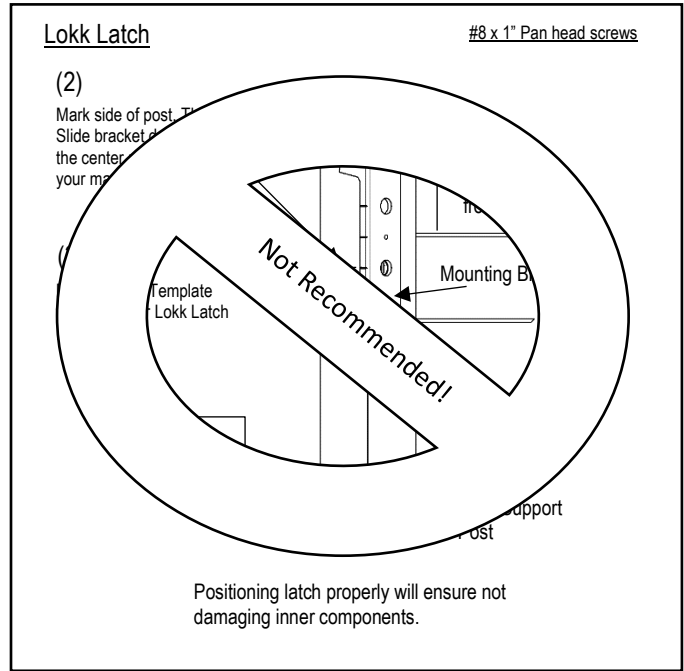

# Bella Cavo Series

(Style C91)

## Gate Installation Instructions



- These instructions must be followed exactly as written, and the materials used must be exactly as shown in the instructions. Any deviation from the instructions or variation in the materials used/installed may result in an unsuccessful installation.

### Hinge Placement

### Latch Placement

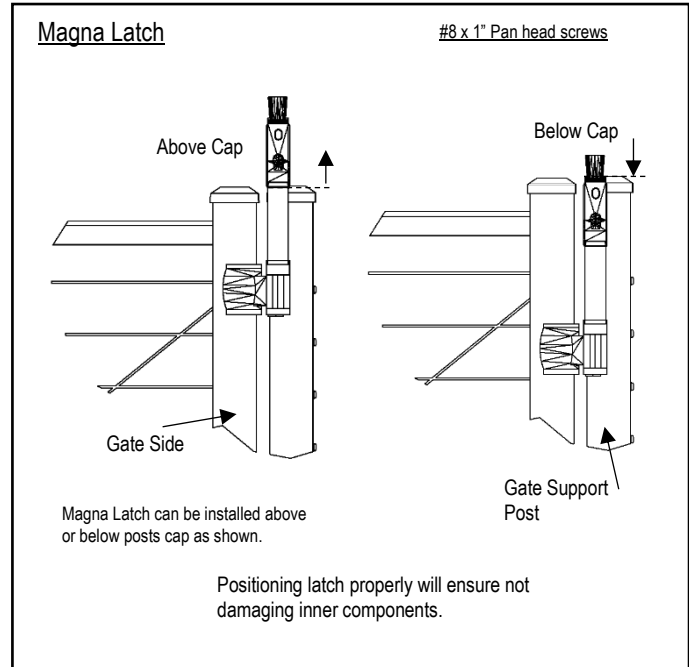
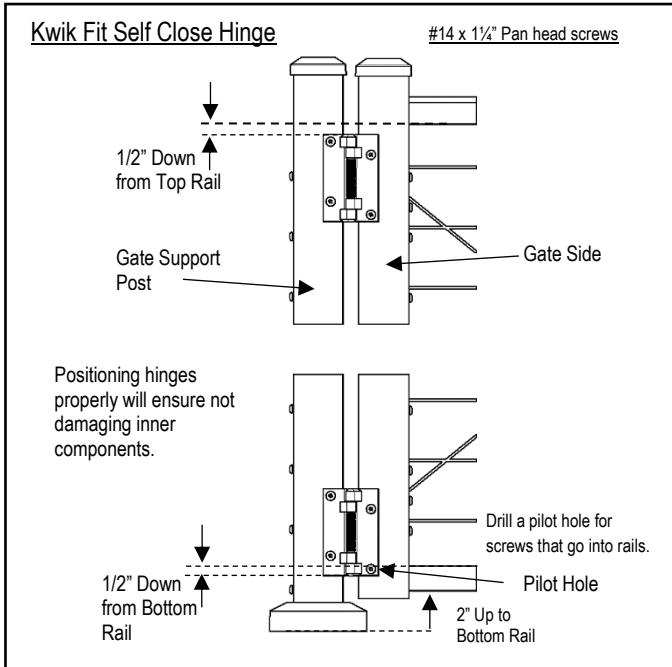

# Bella Cavo Series

(Style C91)

## Gate Installation Instructions



- These instructions must be followed exactly as written, and the materials used must be exactly as shown in the instructions. Any deviation from the instructions or variation in the materials used/installed may result in an unsuccessful installation.

### Standard Width Gate

1. Position hinges on gate. It is recommended to install the hinges on the gate side with shoulder bolts. **Note:** Bella Cavo gate sides and support post include inner components. Therefore, when attaching hinges see the help sheet above for the style of hinge you are using for proper placement. Positioning the hinges properly will ensure not damaging inner components.

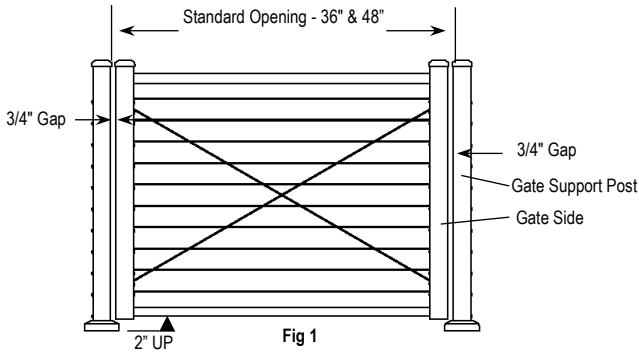

2. Position gate 2" up from the deck as shown in (Fig 1). Attach to support post.
3. If cables are loose and need to be tightened, go to *Special Width Gate* step 11.
4. Position latch on gate. Note: *Square up gate before attaching latch. See Special Width Gate step 12. For latch placement see the help sheet above.*

### Special Width Gate

1. Before attaching hinges to gate. Disconnect all cables from gate side (side with T30 shoulder bolts). To remove cable, use a T30 Torx bit to loosen shoulder bolts. Turn counterclockwise until the cable releases. (See Fig 2)
2. Reset the jaws inside the gate side until they are even with the inner surface of the gate side. **Note:** If you insert a cable into jaws and they don't grip the cable, the jaws are not set properly. To properly set, slowly turn the T30 pan head counterclockwise until you reach the limit. (Cable release position) Then, slowly rotate T30 pan head clockwise; stop when jaws move inside gate side. (Cable engagement position)

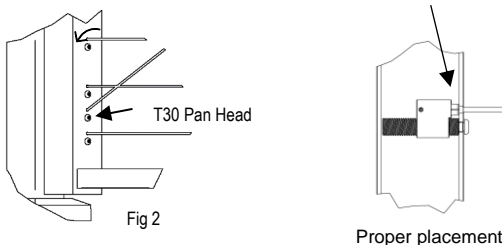

3. Remove gate sides and gate rails.
4. Measure the distance between gate support post and subtract 1 1/4" (Fig 3).

### Special Width Gate Cont'd

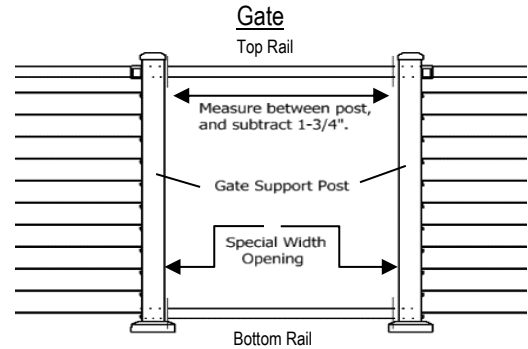
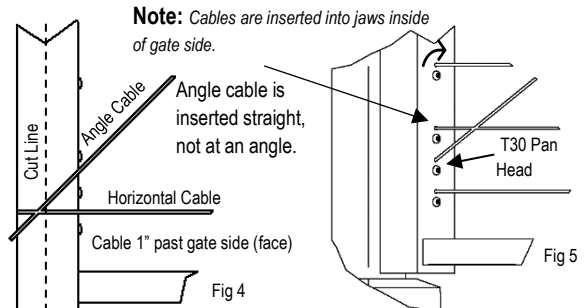

Fig 3

5. Cut top and bottom rails to measurement.
6. Replace top and bottom rails into gate side. Place gate side back onto rails.
7. Place cables on the face of gate side and mark cable 1" past gate side (face). **See Cut Line** (Fig 4)



8. Cut horizontal cable with bolt cutters.
9. Cut angle (Brace) cable with bolt cutters.
10. Reinsert the cables into the jaws until they are fully seated. (Fig 5)
11. To tighten the cables, (T30 Torx Bit) turn the shoulder bolts clockwise until the cable is taut. **Use a standard drill with a clutch. Set clutch to the middle setting for moderate torque. Do not over tighten cables.** If your cable is still loose after tightening, your cable is too long. Remove cable and trim accordingly. **Note: Do not cut too short.**
12. To square up the gate, adjust the cable brace (Angle Cable) by adjusting 1 of the 2 shoulder bolts either clockwise or counterclockwise. **Note:** If you max out on your adjustment, release cable and shorten cable accordingly.

# Bella Cavo Series

(Style C91)

## Gate Installation Instructions



- These instructions must be followed exactly as written, and the materials used must be exactly as shown in the instructions. Any deviation from the instructions or variation in the materials used/installed may result in an unsuccessful installation.

### Warranty

For product Warranty and Registration please scan below:



SCAN ME

### Care and Cleaning

Remove all particles and residue from Westbury aluminum components by referring to the Care and Cleaning requirements on the DSI website. Scan Below:



SCAN ME