

Regis 5000 Series



Installation Instructions

- It is the responsibility of the installer to meet all code and safety requirements, and to obtain all required building permits. The installer should determine and implement the installation techniques appropriate for each unique installation situation. Digger Specialties, Inc. and its distributors shall not be held liable for improper or unsafe installations.
- When core drilling any post product where water can build up, the installer is responsible to drill a ¼" hole as close to the bottom of the post by concrete as possible. If there is no weep hole, you may have damage from moisture build up and freezing.

Step 1: Layout the Fence Line

1. For a standard 8' section post spacing is 96" from center to center of posts. Determine length of sections needed. A standard 8' section will rack up to 17". NOTE: The center-to-center post distance can vary $\pm 1/2"$.
2. Mark ground where centers of all holes will be. For a 2½" post, center of hole will be 1¼" away from string.
3. Dig all holes. We recommend having bottom of holes below frost line and to bell out bottom of holes to help prevent frost uplift. An 8" to 9" diameter hole is recommended for these posts.

Step 2: Attach Caps to Posts

Caps should be placed on posts before installation. Secure caps by tapping with a rubber mallet.

Step 3: Setting Posts and Sections

To help achieve correct height for posts, set string at a certain height from the ground. The following example is using a string set 10" off the ground.

Example: 60" tall 5230 is 61" from ground level to top of post; subtract 10" (amount string is off the ground) from 61" (post height out of ground) = 51". Use a pencil to mark 51" down from the top of all the posts.

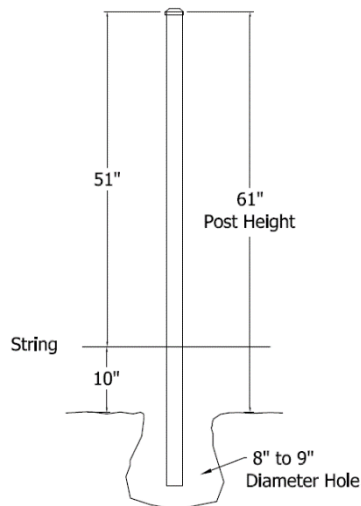

Step 3: Setting Posts and Sections cont'd

1. Pour approximately half a bag of concrete mix into the hole.
2. Place post into hole with concrete.
3. Insert section.
4. Place next post in hole with concrete. Level the post and section to correct height according to the height of the fence.
5. Pour more concrete around posts. We recommend concrete to be at least 8" below the ground.
6. Using a rod (or something similar), run it up and down through the concrete a few times around the post to help pack the concrete.
7. Repeat above procedure for the next section and post.
8. When all posts and sections are installed, double check all post and fence heights.
9. Add some water to permanently set the posts. Let concrete harden.

Cutting Sections to Length

1. Determine length of section needed (measurement from inside to inside of posts plus 1½").
2. Center section between posts, mark and cut section.
3. Notch end of rails using Notching Tool and install as above.

Replacing a Picket

1. Determine which side of the picket the e-clip is located. (All e-clips will be located on same side in section).
2. Take a flat head screwdriver under rail between picket and e-clip.
3. Slide away from picket.
4. Do this for all rails.
5. Insert new picket with pre-drilled holes facing e-clips.

Regis 5000 Series



Installation Instructions

- It is the responsibility of the installer to meet all code and safety requirements, and to obtain all required building permits. The installer should determine and implement the installation techniques appropriate for each unique installation situation. Digger Specialties, Inc. and its distributors shall not be held liable for improper or unsafe installations.
- When core drilling any post product where water can build up, the installer is responsible to drill a ¼" hole as close to the bottom of the post by concrete as possible. If there is no weep hole, you may have damage from moisture build up and freezing.

Replacing a Picket cont'd

6. Slide e-clip towards picket with flat head screwdriver (or finger) until e-clip snaps into picket.

If e-clips need replaced:

1. Using needle nosed pliers, squeeze e-clip together.
2. Twist and pull down.
3. To insert new e-clip, squeeze e-clip together.
4. Twist and insert above track inside of rail.
5. Slide e-clip toward picket with flat head screwdriver (or finger) until e-clip snaps into picket.

Corner Post

When inserting sections into 2½" corner posts, the rails with rail locks will need to be mitered to allow enough clearance so the rail lock will lock into position. After mitering rails, place into the post. Do this for all corner rails.

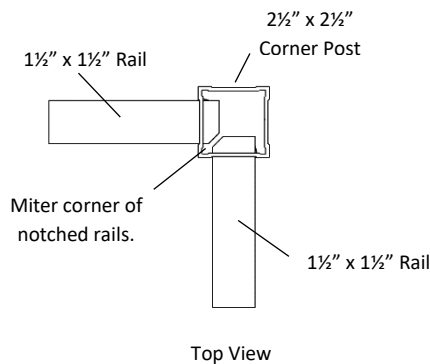

Gate Installation

We recommend using heavy wall (.125") posts on both sides of gates. The gates are preassembled; however, the hinges and latch will need to be applied. Installation Instructions are provided with the gate hardware.

Removing Sections from Post

NOTE: It is recommended to use two Rail Remover tools to remove rails.

1. Insert Rail Remover tools on both sides of rail to allow notches on rail to slide through routed hole in post.
2. Pull rail out of post

Care and Cleaning

Remove all particles and residue from Regis aluminum components by referring to the Care and Cleaning requirements on the DSI website.

