

REV.	DESCRIPTION	DATE
F	56089 replaces 55260. Updated 55239 plate.	02/08/2018
G	Changed 10899 nut to 56422 flange nut; added flat washer 56021.	03/18/2019
H	Added torque value	2/16/2021
I	Replaced 55259 With 110213 & 110214 Mount and Cover	04/14/2023

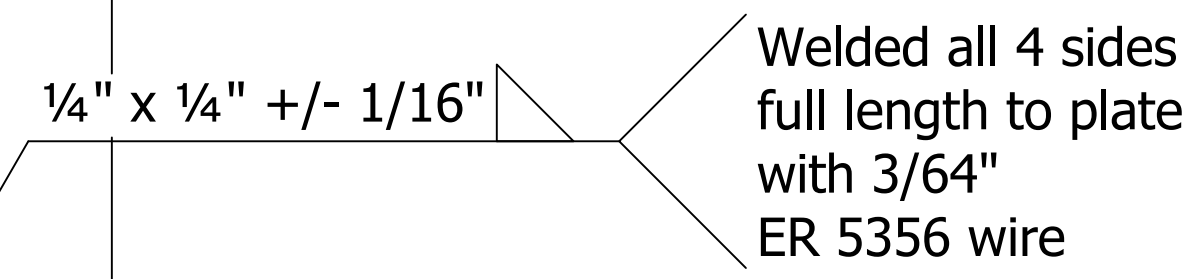

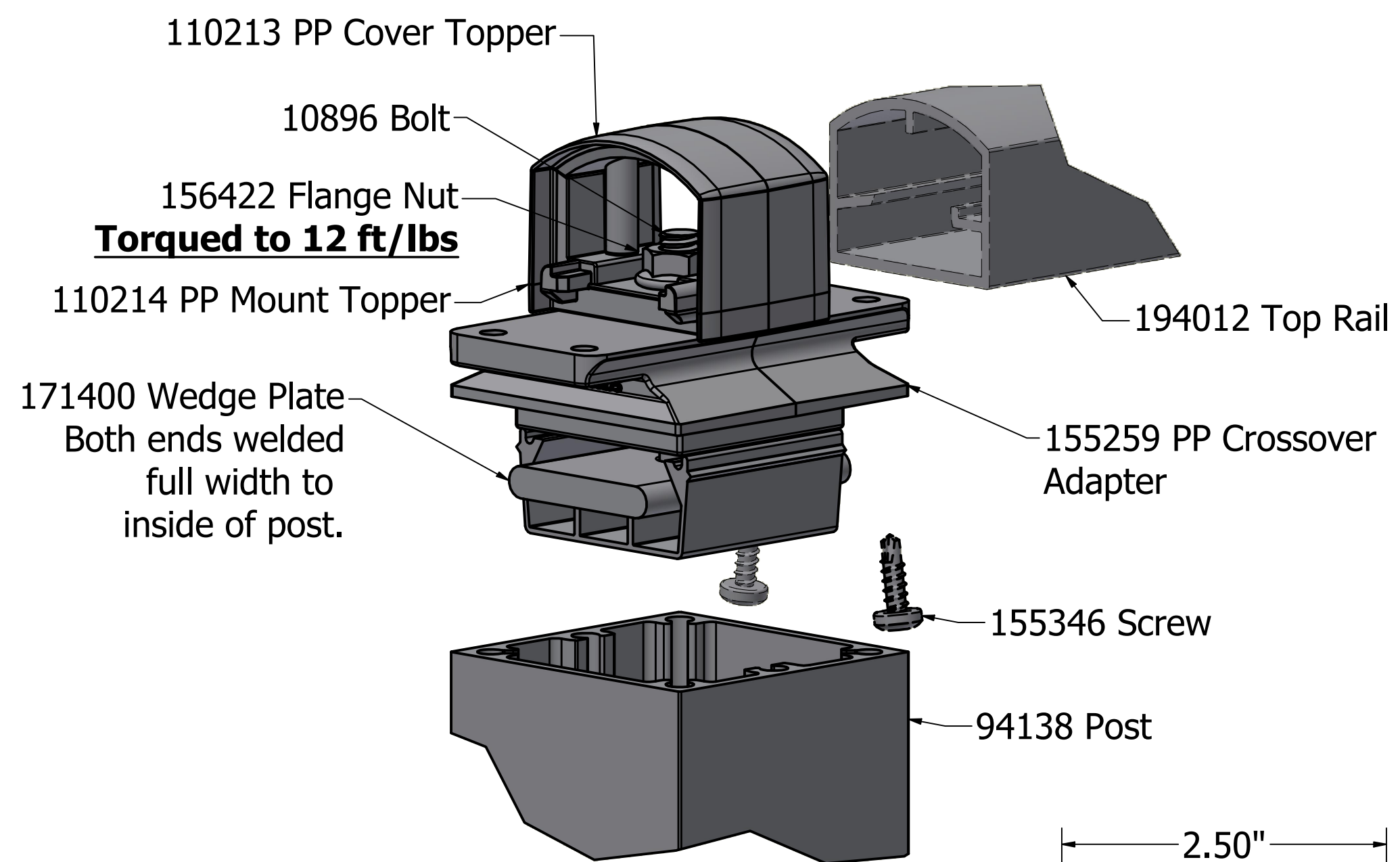
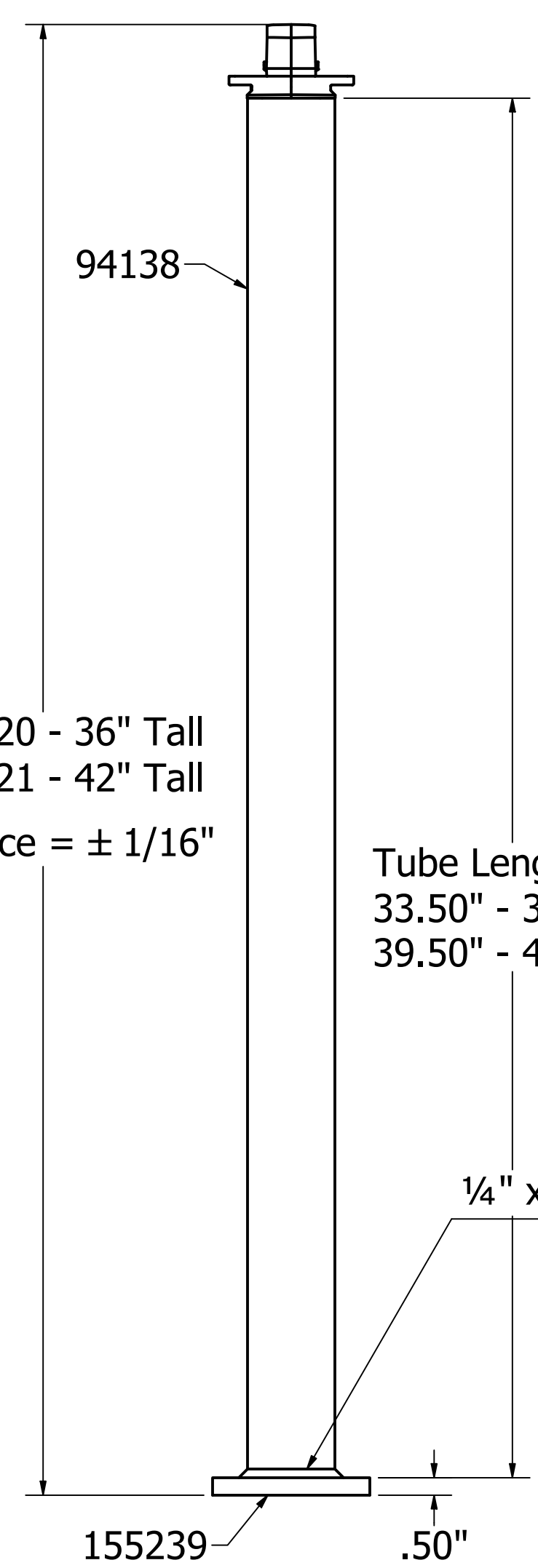
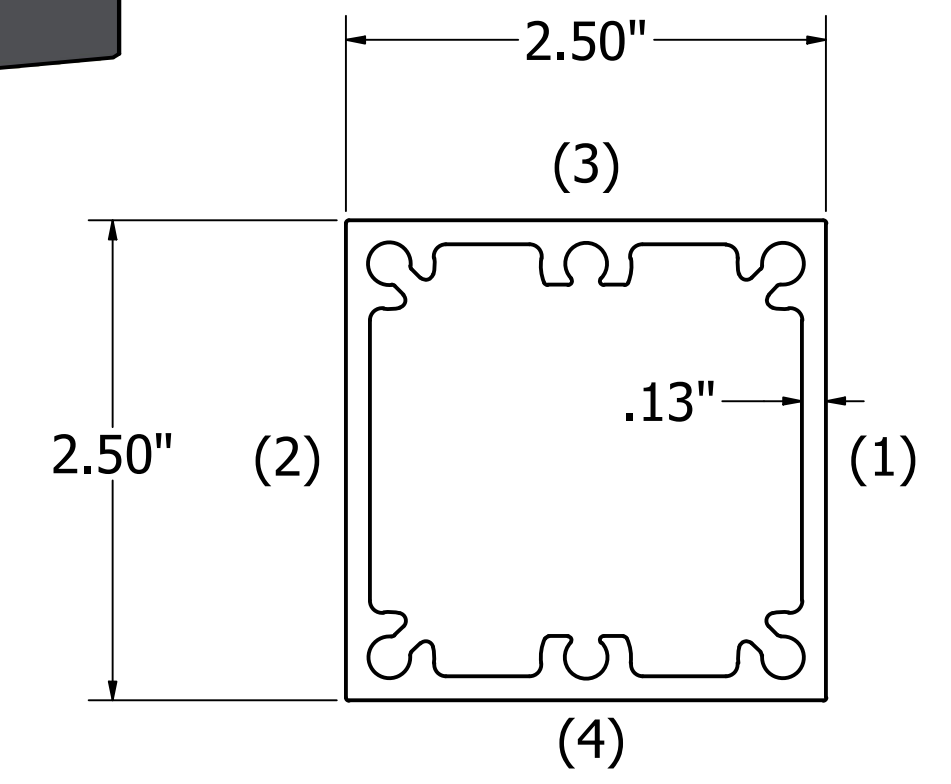

Post and plate must be  
free of dirt and grease  
before welding

Weld sides of post to plate  
in numbered sequence shown.

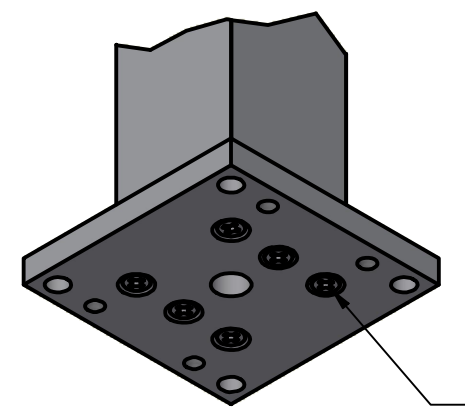

Post must be set to have bottom  
screw line parallel with rail line.



 <p><b>Digger Specialties Inc.</b> <i>Transforming the Outdoor Living Experience</i> 3446 US 6 EAST BREMEN, IN 46506 www.diggerspecialties.com</p>	WEIGHT:	DRAWN BY: FSB	MATERIAL:	
	STANDARD TOLERANCE: .00 \ .01 .000 \ .005 ANG. \ .5~	DATE DRAWN: <b>12/30/2010</b>	PART NAME: 171020 -171021 PP Crossover.idw	
	FRACTIONS: ± 1/16"	DRAFT NO. 20101230-1F	PART NUMBER: 171020 (36" Tall) 171021 (42" Tall)	
	FILE LOC: Z:\Aluminum\Components\Post Mounts, Welded Plates\2.5" Sq. Post\Power Post\171020 -171021 PP Crossover.idw		REV. <b>I</b>	